

SANITISER STATION DISPLAY ASSEMBLY INSTRUCTIONS

SPIGOTED SANITISER BOTTLE DISPENSER ASSEMBLY

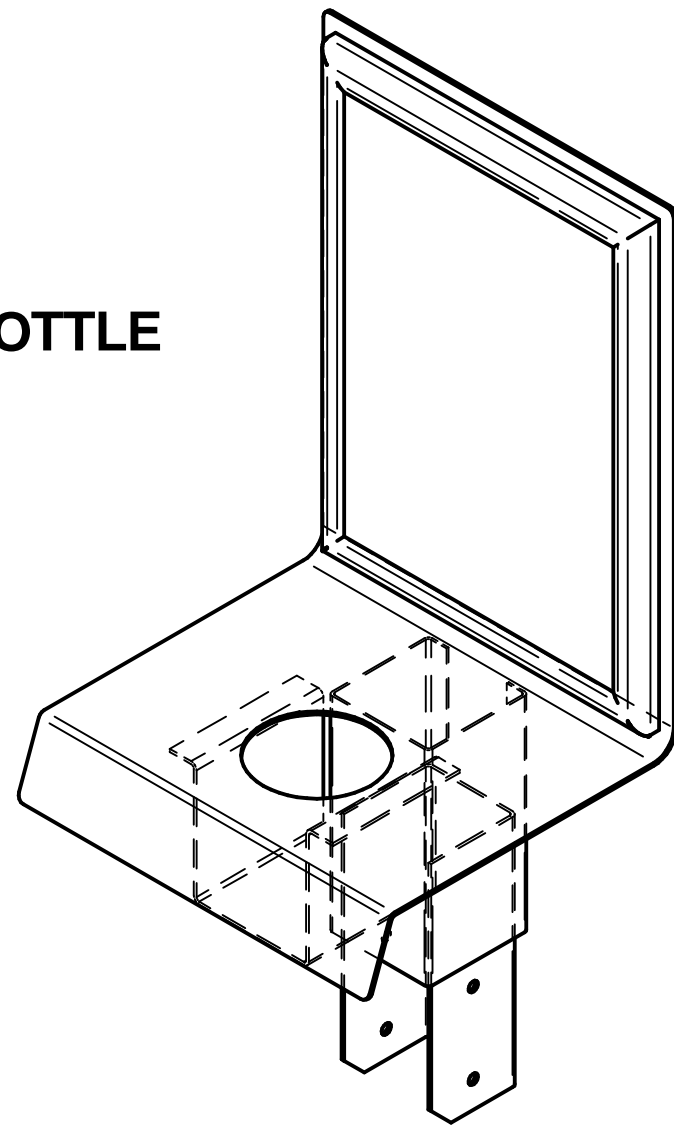

UPRIGHT GLOVE BOX DISPENSER ASSEMBLY (TOP HINGED LID)

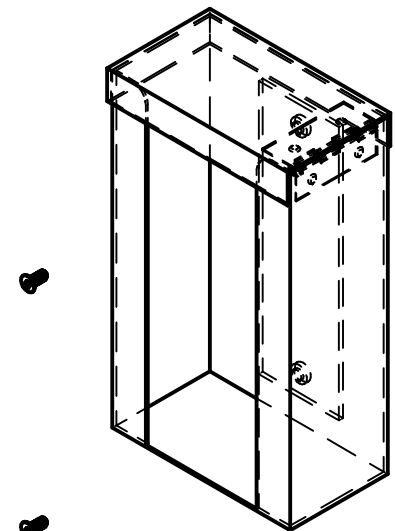

(2 x M5 SCREWS)

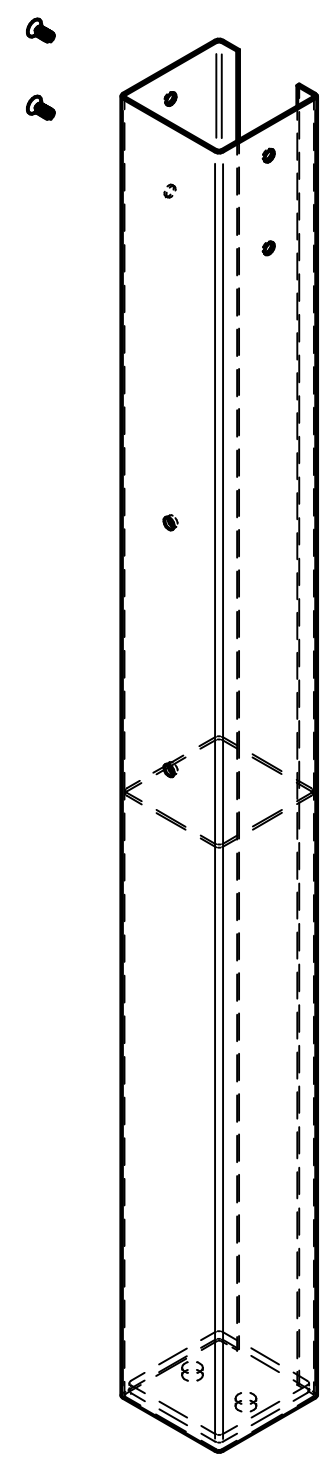

(4 x M5 SCREWS)

UPRIGHT SQUARE POST ASSEMBLY

CIRCULAR BASE

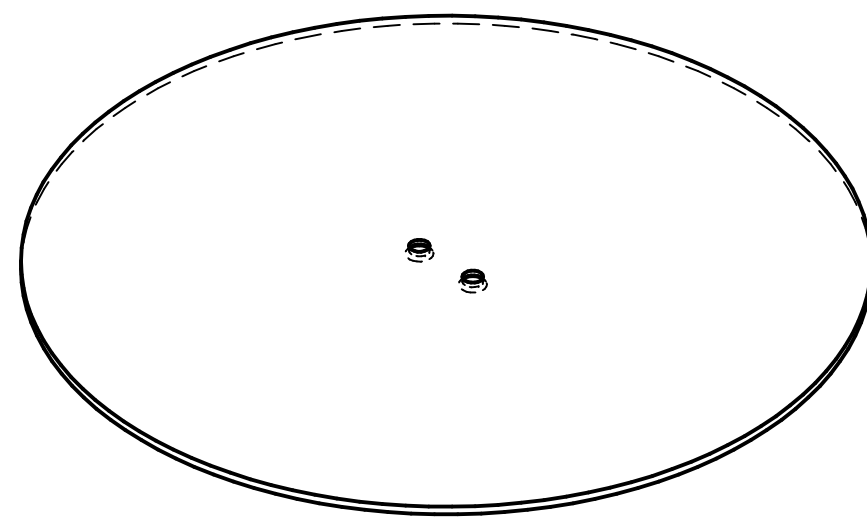

(2 x M8 SCREWS)

KIT SUPPLIED INCLUDES THE ABOVE 4 PRE-ASSEMBLED COMPONENTS
WITH 6 x M5 SCREWS
2 x M8 SCREWS
2 x ALLEN KEYS

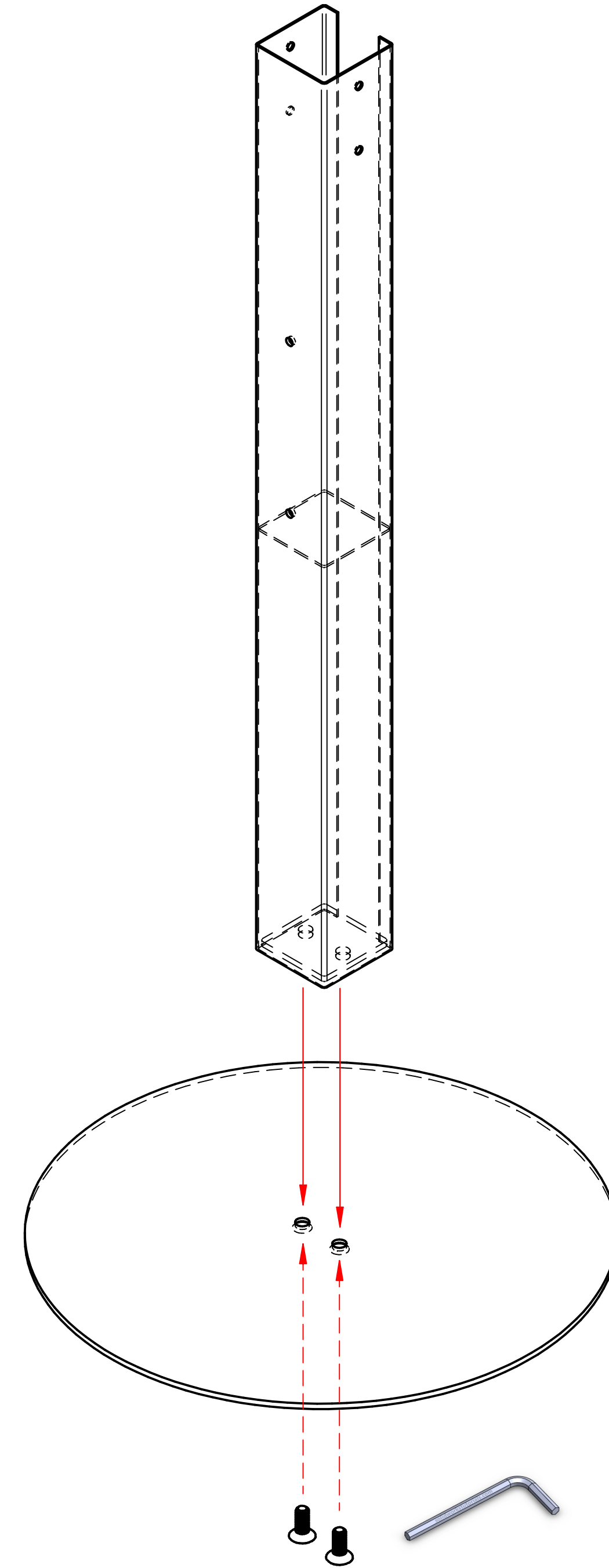

STEP 1:
CAREFULLY LOWER THE UPRIGHT POST ONTO TOP OF BASE BY ALIGNING/LOCATING THE CORRESPONDING 2 HOLES OF EACH COMPONENT. ONCE THE POST IS CORRECTLY LOCATED IN POSITION, INSERT THE 2 x M8 SCREWS PROVIDED & SECURE TIGHTLY FROM UNDER THE BASE.

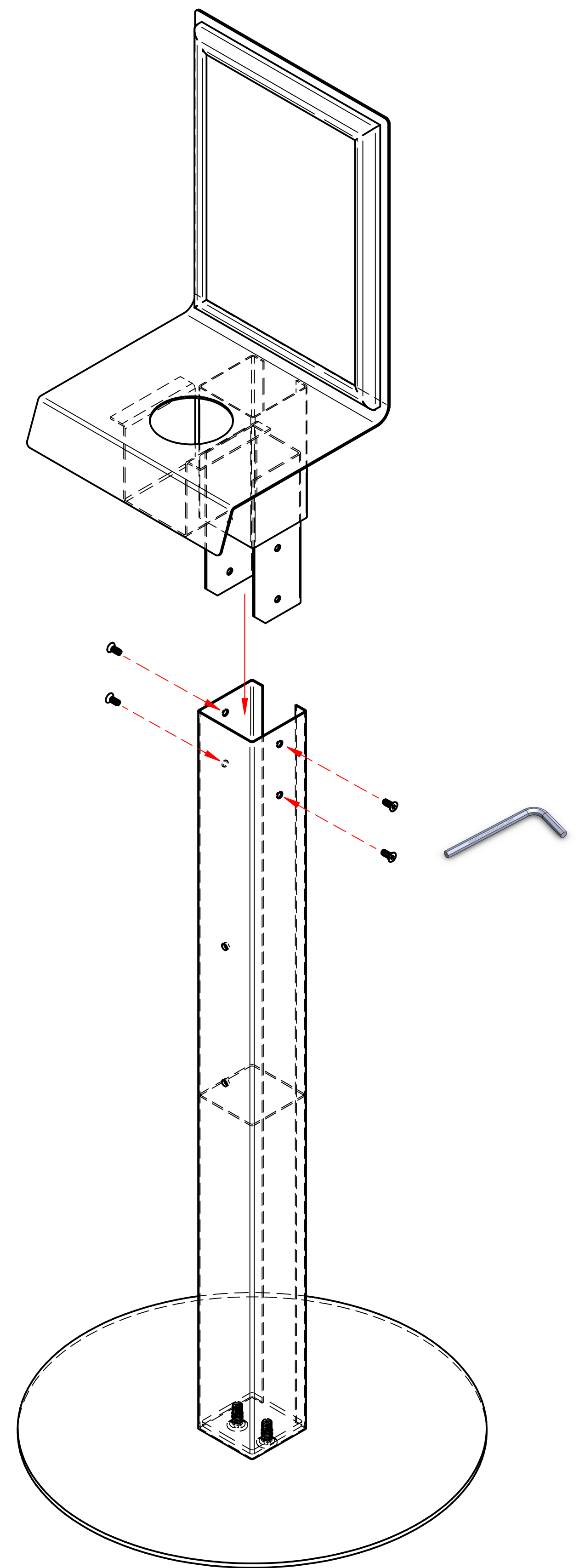

STEP 2:
CAREFULLY SLIDE DOWN THE TOP SPIGOTED SANITISER BOTTLE DISPENSER ASSEMBLY INTO TOP OPENING OF UPRIGHT POST. ONCE THE TOP DISPENSER IS CORRECTLY LOCATED IN POSITION, INSERT THE 4 x M5 SCREWS PROVIDED & SECURE TIGHTLY FROM THE SIDES. (2 FIXING POINTS EITHER SIDE)

SANITISER STATION DISPLAY ASSEMBLY INSTRUCTIONS

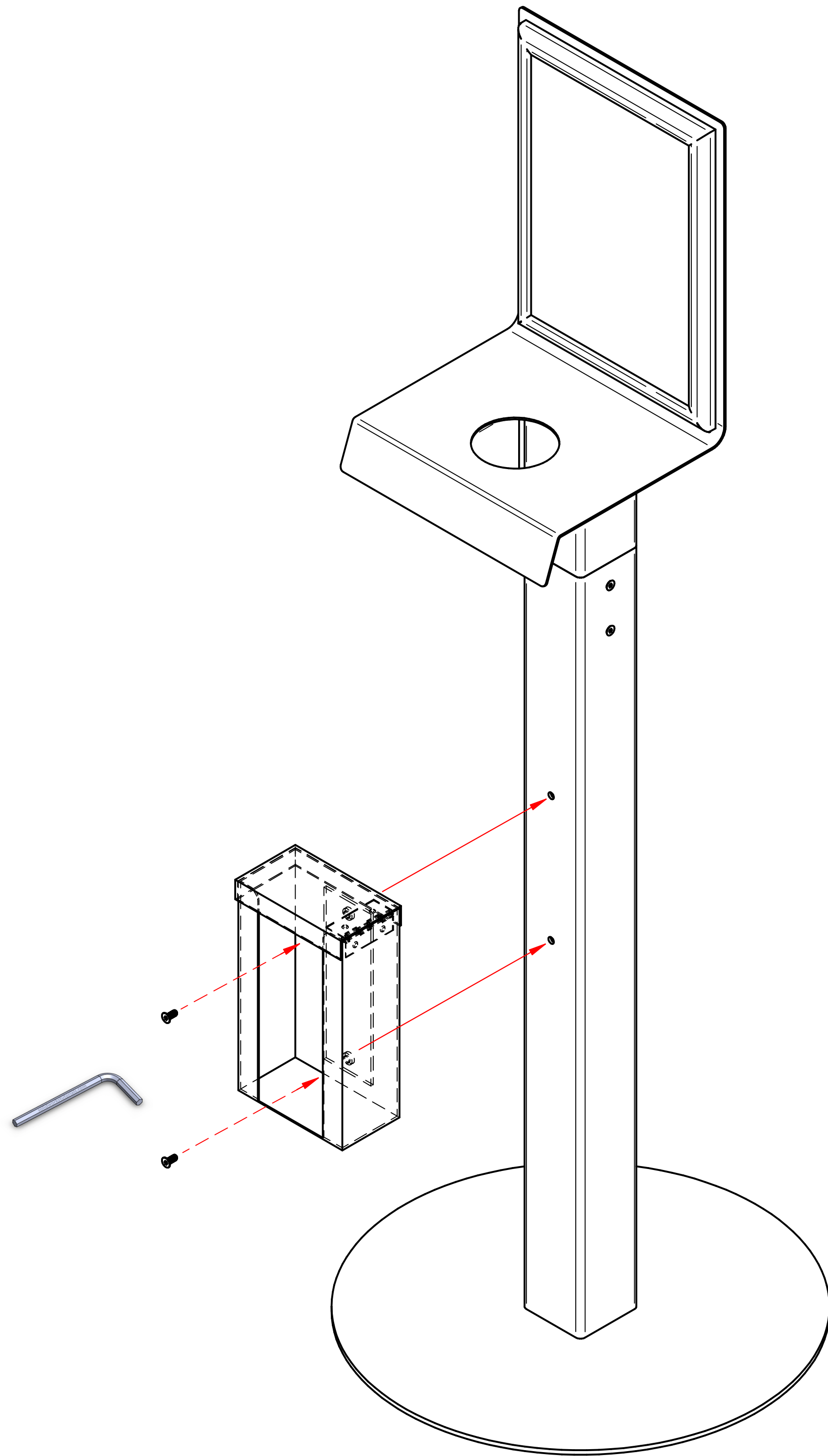

STEP 3:
CAREFULLY LOCATE THE UPRIGHT GLOVE BOX DISPENSER ASSEMBLY TO FRONT FACE OF UPRIGHT POST USING THE 2 FRONT CORRESPONDING HOLES.
(ALLOW THE HINGED LID TO SIT ON TOP)
ONCE THE GLOVE BOX DISPENSER IS CORRECTLY LOCATED IN POSITION, VIA THE FRONT OPENING, INSERT THE 2 x M5 SCREWS PROVIDED & SECURE TIGHTLY.

500ML HAND GEL SANITISER BOTTLE

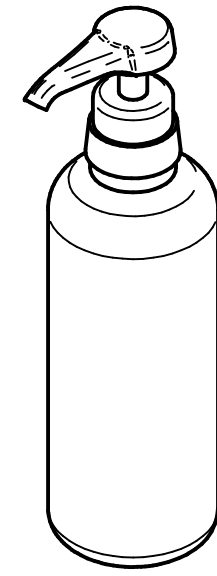

UPRIGHT GLOVE BOX

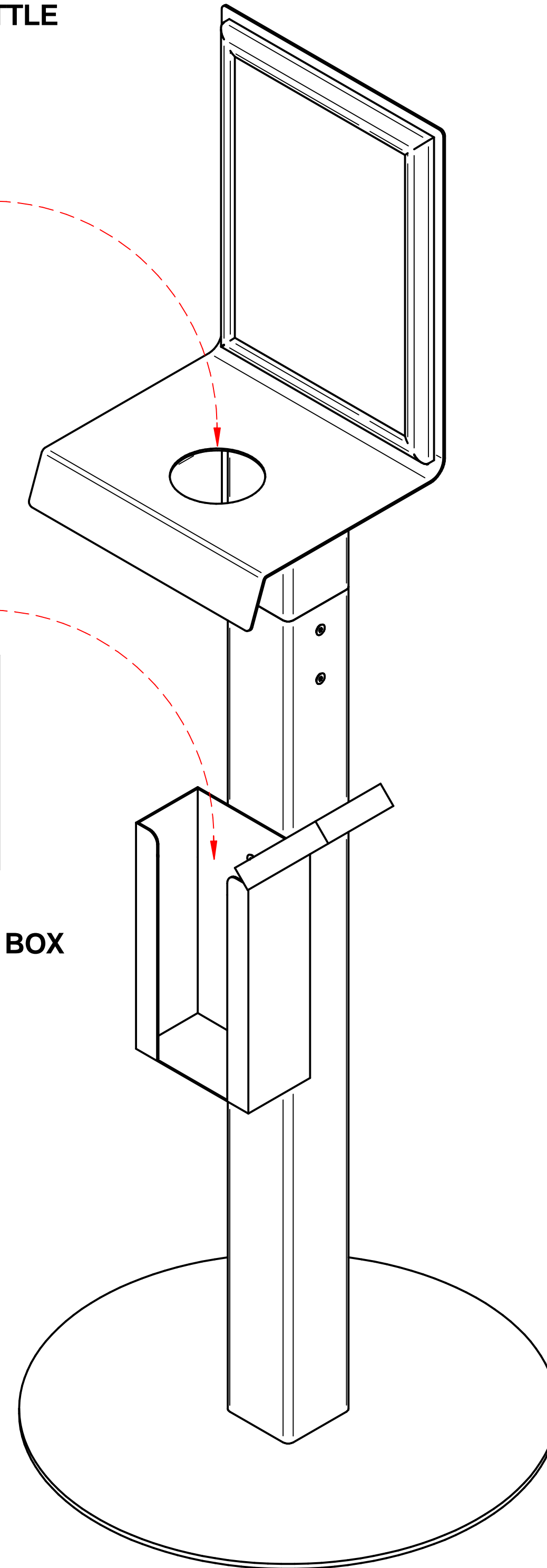
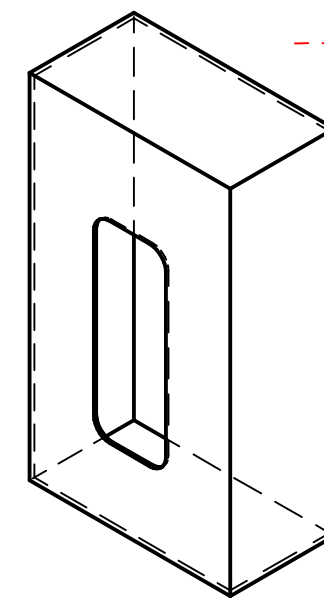

PRODUCT LOADING:
CAREFULLY LOCATE/SLIDE THE 500ML HAND GEL SANITISER BOTTLE VIA THE TOP CUT-OUT HOLE AS SHOWN ABOVE.

RAISE THE GLOVE BOX DISPENSER HINGE & CAREFULLY DROP IN THE GLOVE BOX AS SHOWN ABOVE.
(ALLOW THE FRONT OPENING OF THE GLOVE BOX TO FACE OUTWARDS)

A4 UPDATABLE POSTER FRAME:

THE 4 SIDES OF THE SNAP FRAME CAN BE FLIPPED OPEN TO INSERT YOUR A4 PRINT BEHIND A FLEXIBLE CLEAR PLASTIC COVER SHEET.



FINISHED DISPLAY UNIT