

Universal Light Fitting

The Universal Light Fitting allows our Powerspot lighting units to be fitted to most displays, from banners to pop-ups to linear systems.

features & benefits

- Can be used to fit lights to most banner stands, pop-ups, linear and gantry systems
- Strong and durable moulded fixing
- Supplied with screwdriver

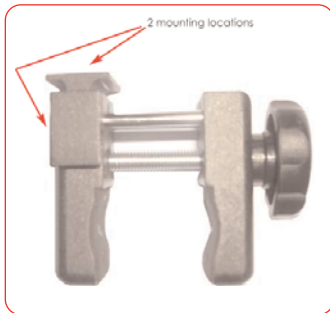

Banner Fixing



Panel Fixing



Pop-Up Fixing



Linear Fixing



(Alternative light fixings for linear systems are codes LNB and US.Linear)



US.Linear Linear channel

LNB - panel fixing



hardware specifications

Clamp dimensions:
75mm x 54mm x 37.5mm

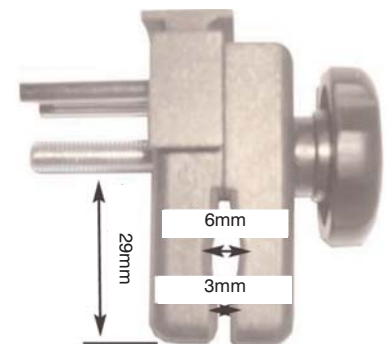
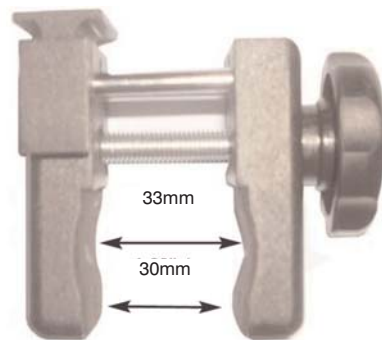
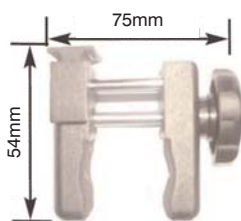

Assembly Instructions

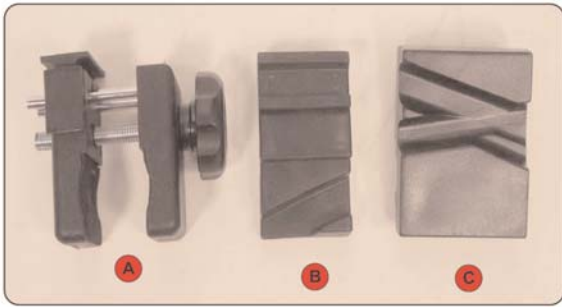

Kit includes: (A) Clamp, (B) Pop-up fitting, (C) Universal/Spyder fitting

Banner Fitting



Slide the clamp onto the light fitting. Then, loosen the clamp.



Place the clamp on the post and hold it there while tightening.



The finished light should look like this.

Panel Fitting

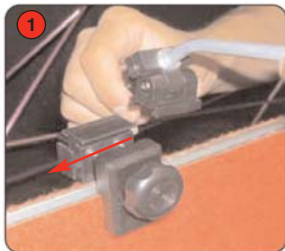

Fit clamp to panel, then slide in light fitting to secure.

Gantry Fitting



The light can be mounted on a gantry system using the same method used for panels.

Pop-Up Fitting



Another way to mount our light is on a pop-up. For this you need the pop-up light clip.



Slide it on with the clip hanging off the back of the light.



Slide it on the right side between one of the cross sections of the pop-up.



Make sure that it is under the back pole and over the front pole.



This is what it should look like.

Linear Fitting



Simply slide the clamp fitting onto the light and fix onto the linear beam, tightening the knob to secure.