

Counters

Vector Counter Curved

V1



Strong and stylish finish counter built-in from modular Vector profiles system. Available in custom sizes. Manufacture to order.

Product Features

- Frame made from 50mm aluminum Vector extrusion
- Rounded corners for maximum graphic coverage
- Thermoformed top and shelf included
- Table top is a single unit
- Silicone Edged Gasket (SEG) Dye-sublimated fabric graphic
- Optional carry bags available and sold separately
- Manufacture to order
- Simple push-fit assembly with easy to follow numbering system

Recommended accessories:



Carry bags for shelf and tabletop AB916



Carry bag kit for counter AB120AC-KIT

Custom Features

- Tabletop and internal shelf available in four colours :
- Available in custom sizes

Recommended Substrate

- Silicone Edged Gasket (SEG) Dye-sublimated fabric
- Visible dimensions : 1000 (h) x 2300 (w) mm

The graphic templates made available are provided for information only. They take into account internal processes which may vary depending on your print facilities, choice of material & finishing techniques. If you are printing the graphics, is your responsibility to test the compatibility of your media with the product before use.



Easy to follow numbered sections



Counter back with inside shelf



SEG graphic with PVC support

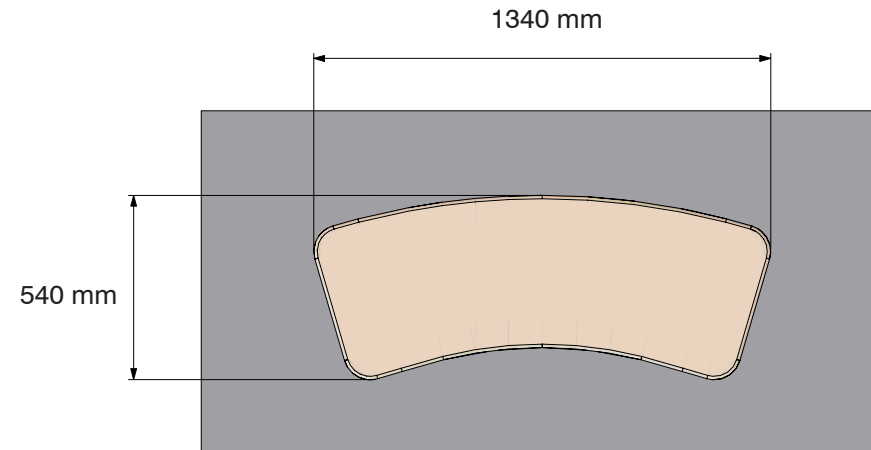
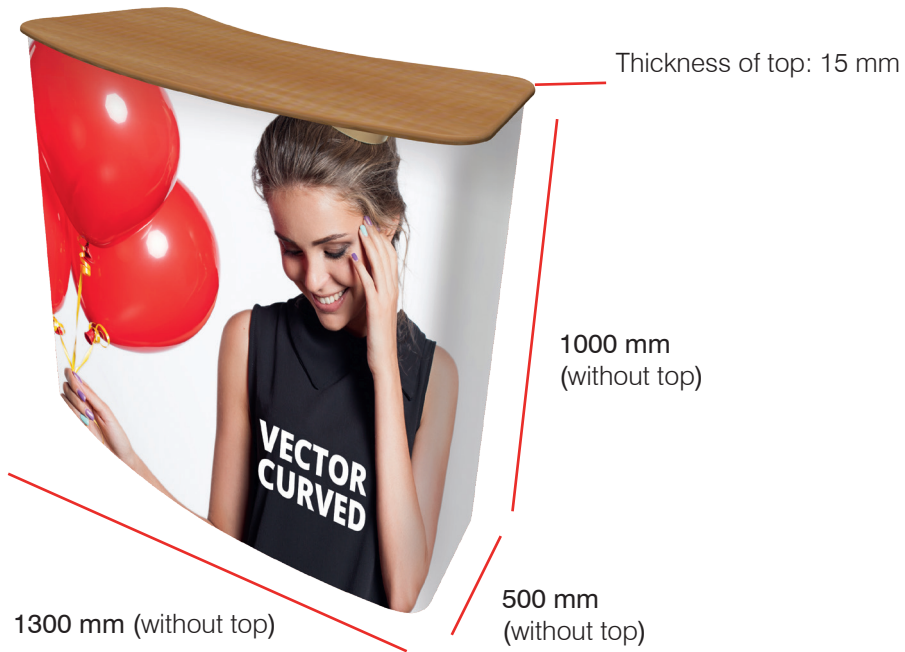

Structure Information

Product Code	Product Name	Assembled dimensions including shelf (mm)	Total Weight	Dimensions colis (mm) h x l x p	Poids colis
VCCB	Vector Counter Curved (Frame, top and shelf)	1015 (h) x 1340 (w) x 540 (d)	18.4 kg	Structure : 1300 x 300 x 200 Tablette + étagère : 135 x 600 x 150	12,80 kg 9,40 kg







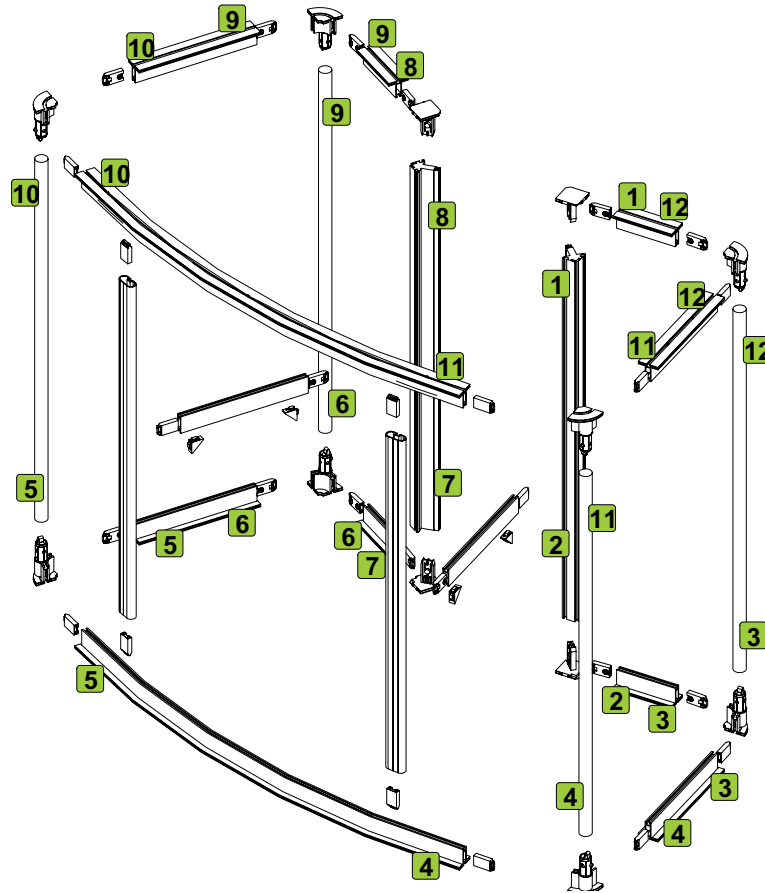



Counters

Vector Counter Curved

Follow the simple marking and coding system to assemble the counter



Frame Components

- 2 X  **LN612-COURBE-SS-1204mm**
Internal Radius: 2077mm
- 4 X  **Vector Beam LN612-SS-310mm**
- 4 X  **Vector Beam LN612-SS-150mm**
- 2 X  **Vector Beam N605-325mm**
- 4 X  **Formulate Tube EXT189-910mm**
- 2 X  **Vector Beam EXT620-SS-986mm**
- 2 X  **Vector Beam LN619-910mm**
- 4 X  **Corner Reinforcement LN116**
- 28 X  **Locks FX617**
- 8 X  **Corner Connector CB10-R**
- 4 X  **Top Cap LN620-TC**

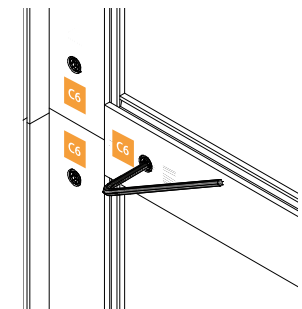

To assemble a cross member and a profile or 2 profiles together, use the Allen key and make a quarter turn.

Counters

Vector Counter Curved

Attaching the Shelf

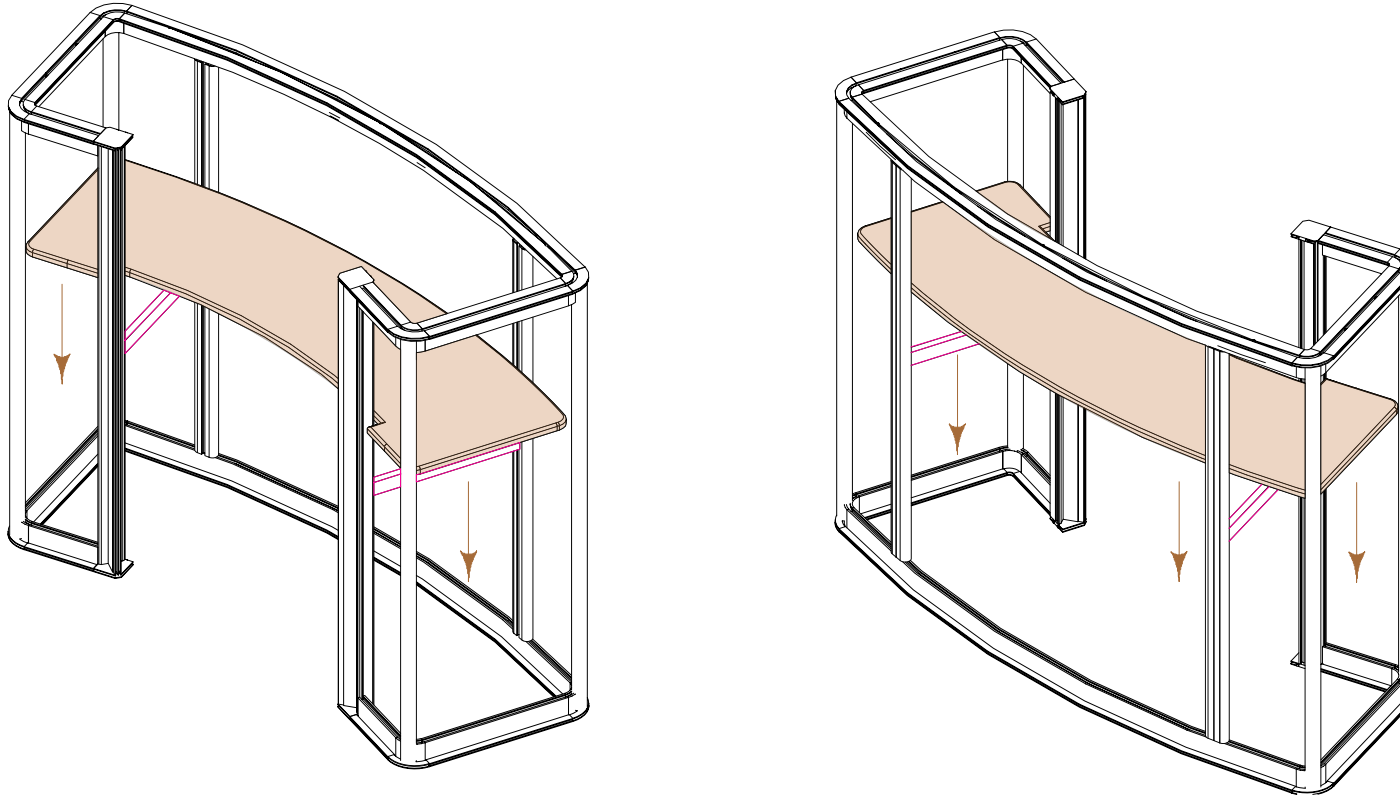

Screwless Attachment: Simply place the shelf on top of the two reinforcements. The shape of the frame and design of the shelf is sufficient to maintain the load.

Counters

Vector Counter Curved

Attaching the Top

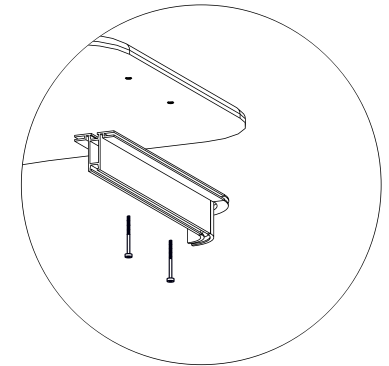
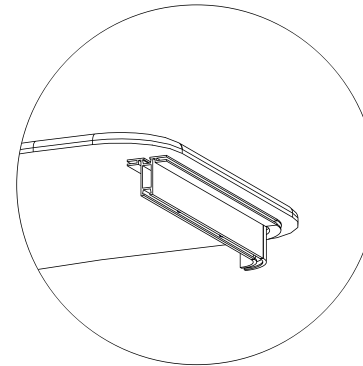
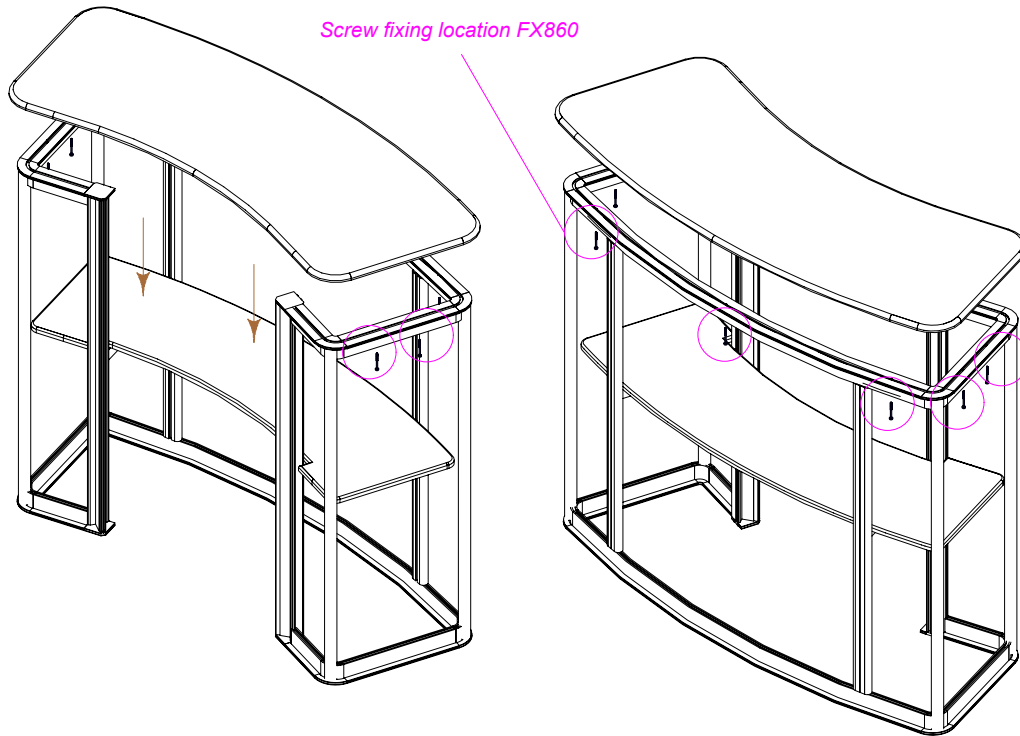

1/ Place the top on the assembled counter and adjust so that the holes are in line with the FX866 threaded inserts (already inserted in the shelf).

2/ Once the top is in place, fix the structure to the tray with the FX860 screws.



Threaded Insert **FX866**



Screw **FX866**

Counters

Vector Counter Curved

Graphic Assembly

Large Format Graphic Printed

The printed graphics have a Silicone Edged Gasket (SEG) which makes their installation simple and quick.

Start by installing the 4 corners of the graphic, then insert the gasket into the middle of each side.

Then, work the gasket from the middle out to the corners, starting from the bottom.

1

Install the gasket into the 4 corners of the frame

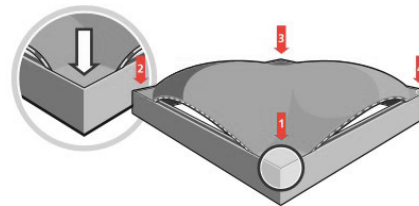

2

Then work the gasket from the middle to the corners of the frame

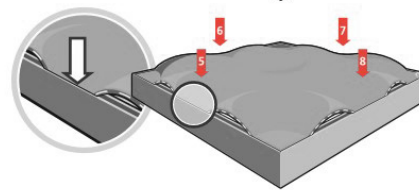

3

Press from the middle to the corners

